

SPECIFICATIONS

CB-3

BRACKETRACK AND KEY-HOLE SLIDING DOOR TRACK SYSTEMS

Self-cleaning, self-aligning! Track retains all these unmatched CannonBall advantages, plus the lifetime guarantee, that builders have preferred for over fifty years.

Matches trim on colored buildings! Track cover comes in white enamel finish to match the trim on colored buildings.

Saves builder's time! Key-Hole Track is easy and fast to install. Shoulder rivets on mounting brackets are simply tapped into slotted key-holes on the track. Bracketrack brackets are pre-riveted on at factory. Mounting brackets are then quickly nailed to the track plank.

Saves builder's inventory! Key-Hole Track is completely interchangeable with all Standard CannonBall Brackets for by-passing, etc. installations. One stock of track handles all applications, inside or outside.

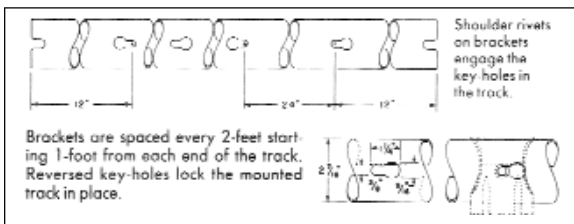
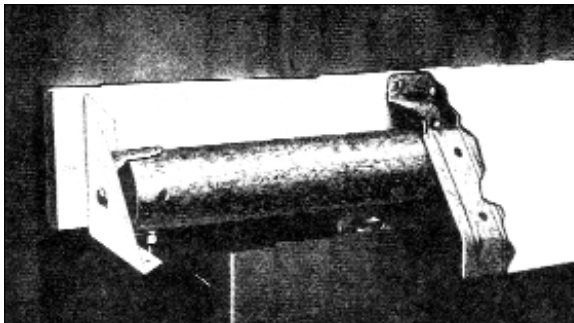

ITEM	KEY-HOLE	ONE-PIECE BRACKETRACK
Track Material:	14 ga. galv. steel	1 4 ga. galv. steel
Lengths available:	6'-20' in 2' increments	6'-20' in 2' increments
Weight per lineal foot:	2.0 lbs.	2.1 lbs.
Maximum door leaf weight with single truck trolley hangers:	400 lbs.	400 lbs.
Maximum door leaf weight with double truck trolley hangers:	600 lbs.	600 lbs.
Mounting Brackets:		
Top mounted track & cover:	646519	attached
Face mounted track & cover:	646513	attached
Track only:	646512	attached
No. required:	1 every 2' of track	attached
Mounting Nails Recommended:	Galvanized ring shank nails: per — one 20d, 4" x 7 ga. or two 16d, 3-1/4" x 9 ga. or two 10d, 3" x 10 ga. or two 8d, 2-1/2" x 10 ga.	
Cover:	28 ga. galv. steel	
White Enamel:	28 ga. galv. steel	
Length:	10'-2"; provides 2" overlap splice every 10'	
Size:	Face mounted brackets for nominal 1" or 2" track plank. Top mounted bracket for 2" planks only.	
End Trim:	Yes	Yes

* BRACKETRACK—WHAT A GREAT IDEA!

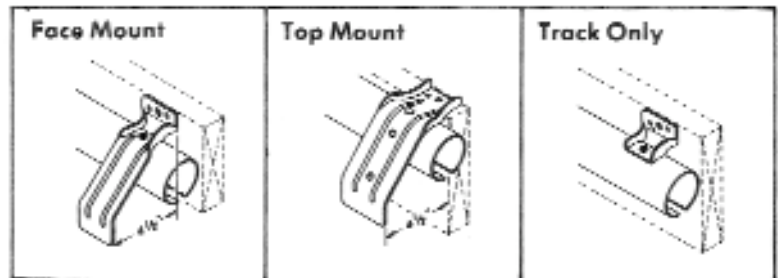

* Same quality as keyhole track, only brackets are pre-riveted on at factory.



Face Mounted Brackets for mounting Track and Cover

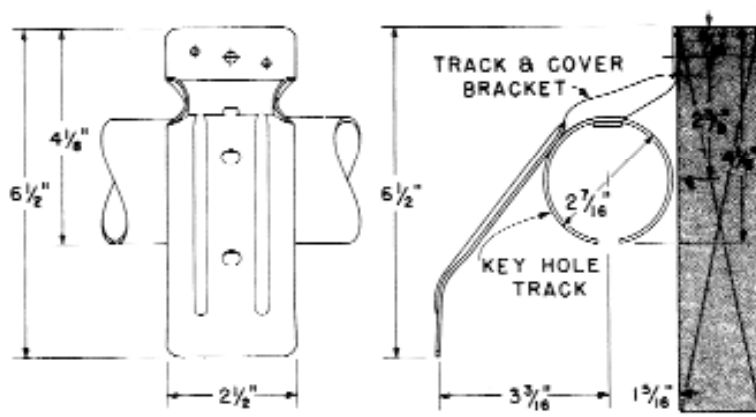

Track and Cover Bracket. For mounting a single run of Track and Cover on a track plank. One required for each 2-feet of track run. Shape of bracket and cover allows plenty of room for both vertical and lateral door adjustment. Galvanized. Packed 50 per carton. (One package handles 100-feet of track). Weight of package 20 lbs.

Scale: $\frac{5}{16}$ " equals 1"

Face Mounted Brackets for mounting Track only

Track Bracket. For mounting a single run of Track (less cover) on a track plank. One required for each 2-feet of track run. Galvanized. Packed 50 per carton (One package handles 100-feet of track). Weight of package 7-1/2 lbs.

Note: 646512 Track Brackets are for use where track cover is not required, such as indoor applications.

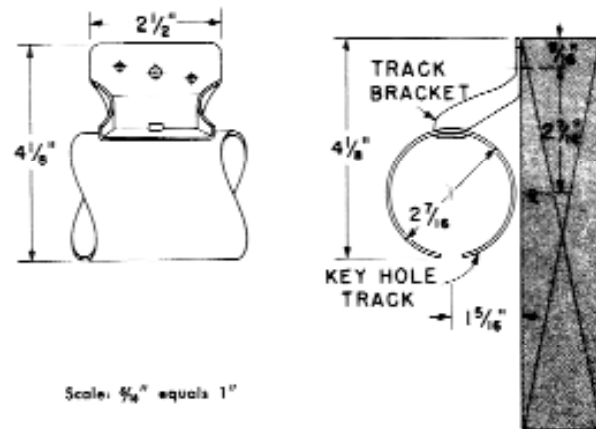

Scale: $\frac{5}{16}$ " equals 1"

Top Mounting Brackets for Track and Cover

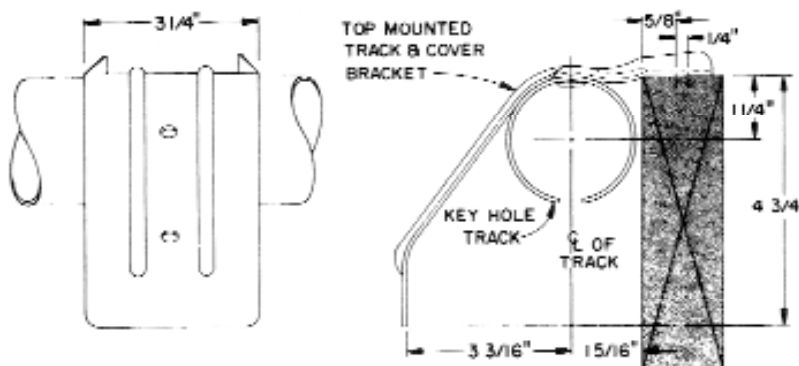

Top Mounted Bracket used with a single run of Track and Cover. Top Mounted on a 2-inch track plank only. One bracket required for each 2 feet of track run. Galvanized. Packed 50 pieces per carton (one package handles 100-feet of track). Weight of package 25 lbs.

Scale: $\frac{5}{16}$ " equals 1"

Covers for Face Mounted and Top Mounted Track

646225 Track Cover (Right)
Shaped to fit nominal 2-inch track plank. Bottom lip hooks over bottom edge of each 646513 Track and Cover Bracket; top edge flashes junction of track plank and siding. Standard length 10 ft.-2 in. White enamel. Packed 20 pieces per carton. Wt./Pc. 8.0 lbs.

646224 Track Cover. (Below)
Same as 646225 except for nominal 1-inch track plank. White enamel. Wt./Pc. 8.0 lbs.

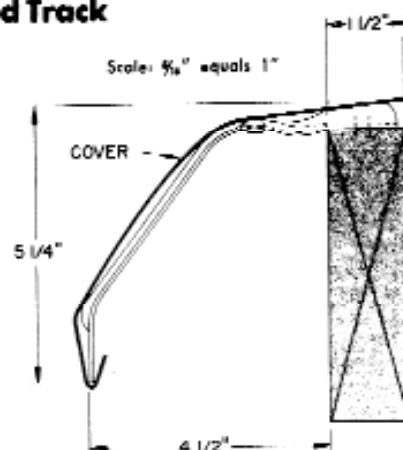
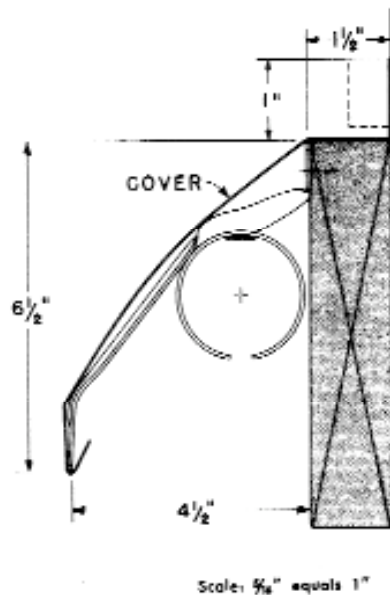
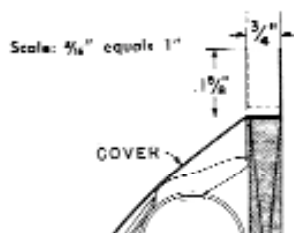

646226 Top Mounted Track Cover.
(above) Shaped to fit nominal 2 inch track plank only. Bottom lip hooks over bottom edge of 646519. Track and Cover. Top Mounting Bracket. Top edge flashes junction of track plank and siding. Standard length 10-foot 2 inch. White enamel. Packed 20 pieces per carton. Weight 8 lbs. per carton.

Note: White enamel cover has base metal of high-tensile cold rolled steel with galvanized protective coating of 1.25 oz. zinc per square foot. Then, a Bonderite zinc phosphate coating prepares the galvanized surface for tight adhesion of a special formula, oven-cured primer coating. Finish coating is an oven cured polyester enamel for maximum durability. A final wax coating adds lustre and protects during shipping and storage.

End Caps and End Trim for Top Mounted Track Cover

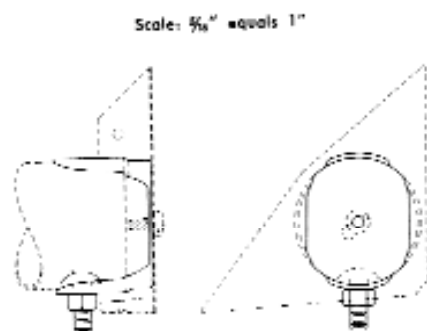

646514 Track End Cap with bolt and nut.
Galvanized. Two needed per track run. Packed 20 per carton with mounting bolts. Wt. of Pkg. 6 lbs.

646515 End Trim. Bird proofs the space between the track and cover and serves to finish off the cover ends. Two recommended for each run of track. White enamel. Packed 20 per carton with mounting screws. Weight of package 6 lbs.

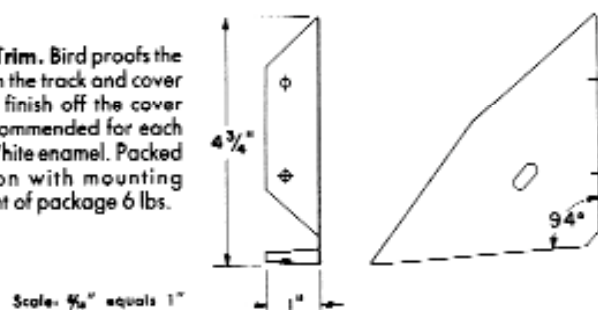

646518 End Trim for Top Mounted Track Cover only. Must be ordered in pairs (one right hand piece and one left hand piece.) White enamel. Packed 10 pair per package. (Enough for 10 runs of track.) Weight 6 lbs. per pair.

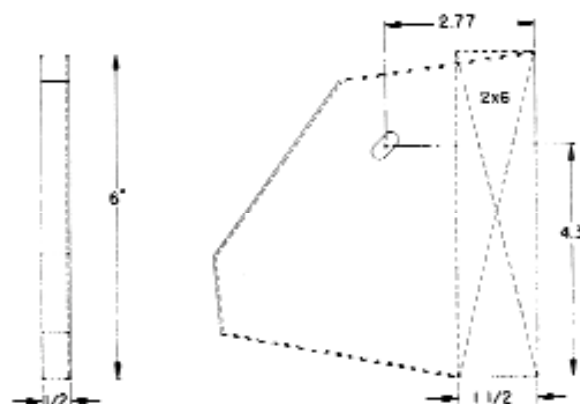

End Trim in place on Track Cover

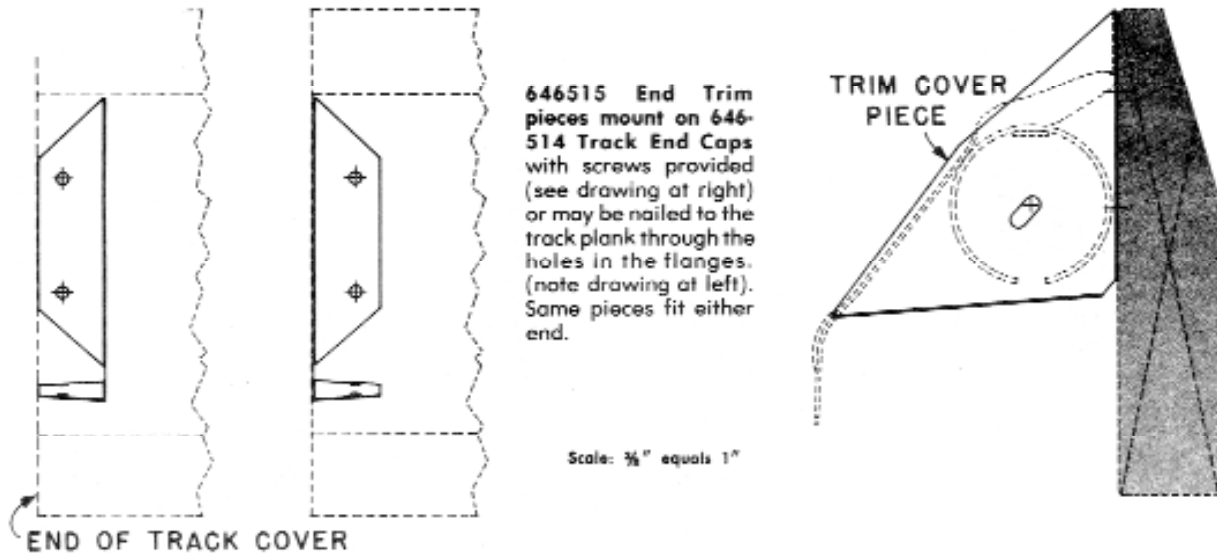

Cover may run beyond end of track

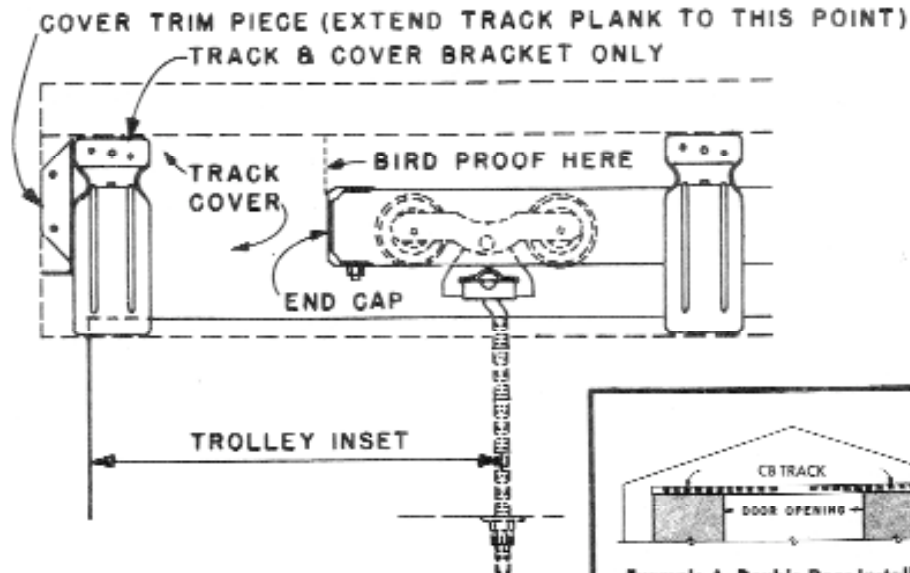

Several feet of Track can be saved on each application by allowing track only where trolleys will run. Then, by permitting cover to extend beyond the track to the extremes of the door movement when in the open position, door tops are protected and a completely finished appearance is achieved. Details in drawing and examples above. The extent to which trolleys may be inset varies with the door leaf shape. They should be inset most on a wide, low leaf.

