



Utility Grade
Aluminum Frame Walk Doors
1700 and 1800 Series



utility grade

Utility Grade - Aluminum Frame Walk Doors

1700 SERIES

1700 SERIES

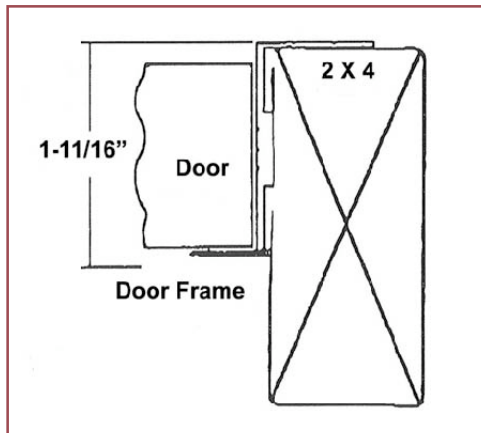

- Full 1-3/8" thick insulated panel
- 1-11/16" Aluminum jamb with nailing flange
- 2-3/4" backset for standard locksets
- Non-collapsible nylon lockset insert
- Zinc-plated steel hinges
- Pre-hung universal swing
- Wrap-around design gives commercial feel to panel
- Economy with durability

1734 SERIES

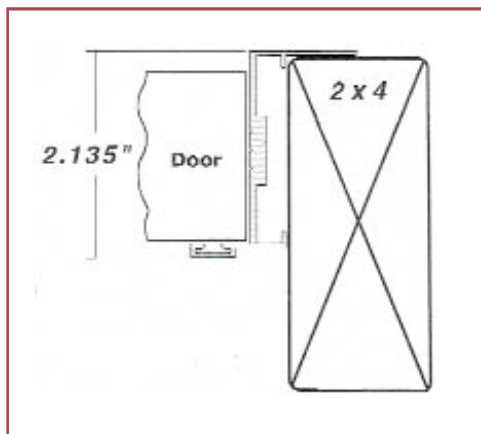

- Full 1-3/4" 4-way universal insulated steel panel
- Frame has common header/threshold and nailing flange standard
- All aluminum pre-painted white frame
- 2-3/4" backset for standard locksets
- Non-collapsible nylon lockset insert
- Low maintenance
- Economy with durability



Options and Accessories:

- Prepped for deadbolt
- Prepped for panic and closer
- Variety of window lites available
- Special lockset prep
- Locksets and deadbolt

utility grade

Utility Grade - Aluminum Frame Walk Doors

1800 SERIES

1822 SERIES

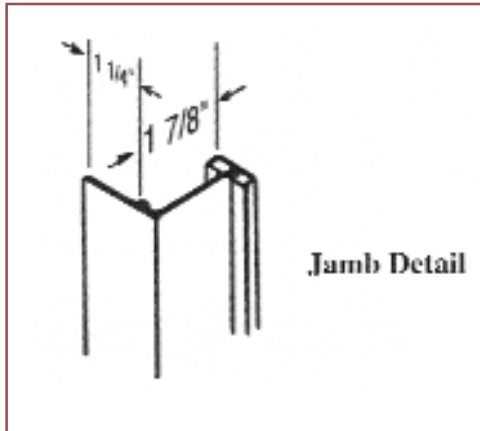

- Pre-hung universal 1-7/8" jamb is standard
- Door may be installed right or left hand, swing in or out
- Optional J trim header for finishing the exterior
- Universal header and threshold
- Available in steel, aluminum and fiberglass door skin
- Stainless steel hinges standard

1852 SERIES • 1872 SERIES

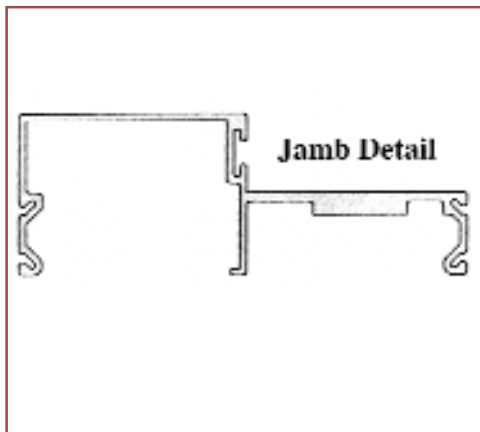

- Pre-hung universal 3-1/2" jamb is standard
- Door may be installed right or left hand, swing in or out
- Optional J trim header for finishing the exterior
- Universal header and threshold
- Available in steel, aluminum and fiberglass door skin
- Stainless steel hinges standard
- Model 1872 features integral nailing flange



Applications:

- Agricultural Buildings
- Storage Buildings
- Garages
- Temporary Structures
- General Utility

Utility Grade 1700 and 1800 SERIES

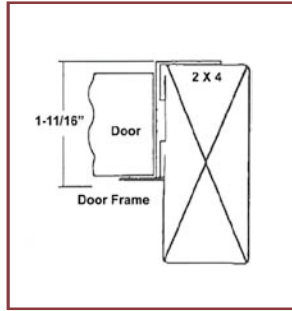

1700 Series

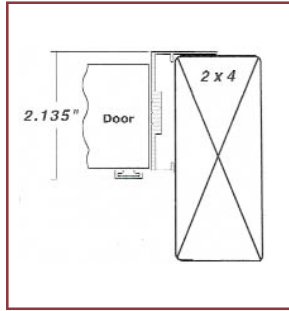

1734 Series

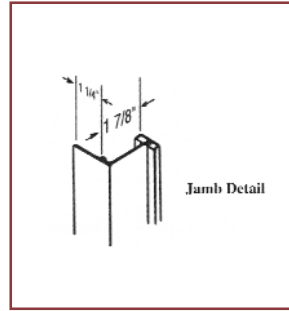

1822 Series

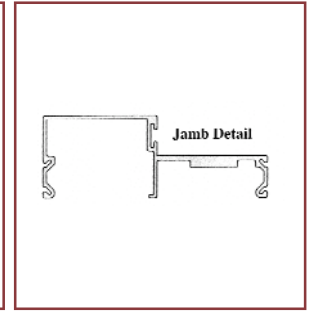

1852 Series • 1872 Series

Skin Type	26 ga. steel	24 ga. steel	Steel, Aluminum, Fiberglass	Steel, Aluminum, Fiberglass
Panel Thickness	1-3/8"	1-3/4"	1-5/8"	1-5/8"
Panel Type	Rolled Insulated	Rolled Insulated	Edged Insulated	Edged Insulated
Jamb Finish	Mill	White	Mill	Mill, White or Brown
Hinges	Zinc-plated	Stainless Steel	Stainless Steel	Stainless Steel
Jamb Depth	1-11/16"	2-1/8"	1-7/8"	3-1/2"
Available in Brown	No	No	Yes	Yes
Nailing Flange	Yes	Yes	Yes	optional (1872)

Out-to-Out Dimensions

2868	N/A		33-3/16" x 81-5/16"	33-9/16" x 81-3/4"
3068	36-3/4" x 80-1/2"	36-13/16" x 80-5/8"	37-3/16" x 81-5/16"	37-9/16" x 81-3/4"
4068*	N/A	46-13/16" x 80-5/8"	49-3/16" x 81-5/16"	49-9/16" x 81-3/4"
6068	N/A	73-13/16" x 80-5/8"	73-7/8" x 81-5/16"	74-3/16" x 81-3/4"

*1822, 1852 and 1872 Series only available with aluminum or fiberglass skins in widths over 36" and height over 80".

Applications:

- Agricultural Buildings
- Storage Buildings
- Garages
- Temporary Structures
- General Utility

