

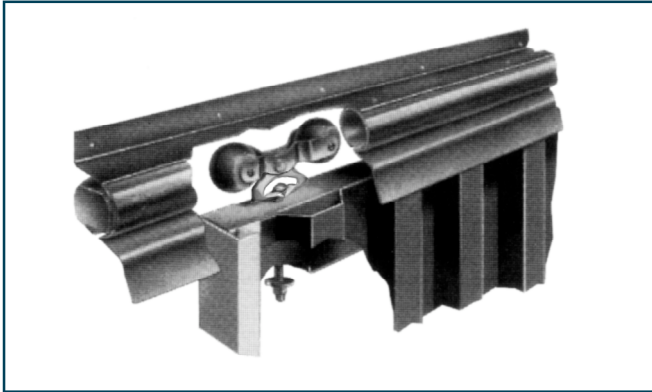

SEAL-TITE™, WEATHERSTRIP™, TUBULAR™ SYSTEMS

Seal-Tite™ Door Track Systems featuring:



- Durable, galvanized construction, ruggedly built to last.
- One-piece construction offers lower on-site labor costs.
- Unique “storm apron” diverts water and acts as a wind deflector.
- Weather protection of doors up to 3 3/4” in thickness and weighing up to 600 lbs. on single trolleys, and 1000 lbs. with double truck trolleys.
- Available in 6-12 ft. lengths.

Weatherstrip™ Door Track Systems featuring:

- An economical system for indoor or outdoor use.
- Galvanized one-piece construction assures longer life.
- Provides weather-proofing and durability at a low cost.
- Weather protection of doors up to 3 3/4” in thickness and weighing up to 600 lbs. on single trolleys, and 1000 lbs. with double truck trolleys.
- Available in 6-20 ft. lengths.

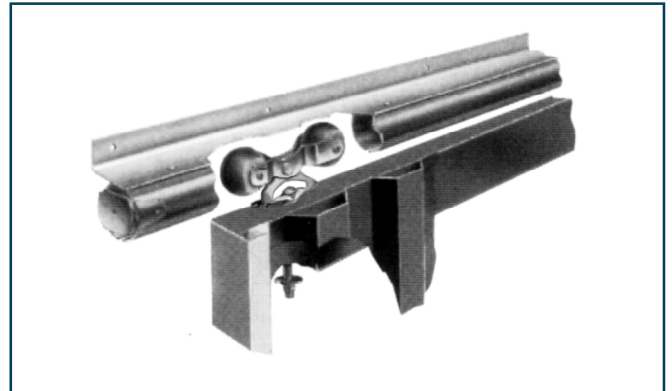

Tubular™ Door Track Systems featuring:

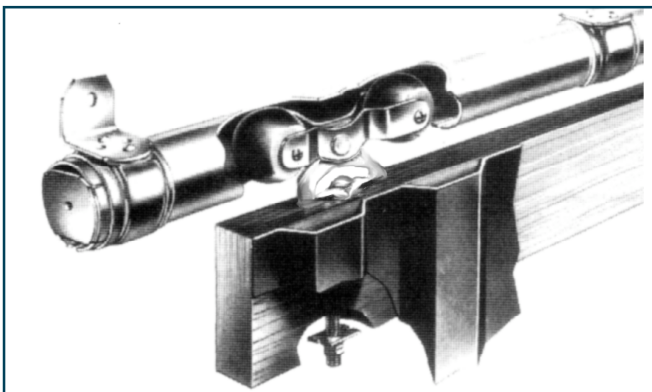

- The perfect track for suspending doors from ceilings, installing by-pass runs, mounting on inside openings, or for use outside where weather is not a concern.
- Constructed of 13 gauge galvanized steel for maximum strength and durability.
- Supports doors up to 1200 lbs.* when used with double truck Delrin hangers with brackets on 12” centers.
- Available in 6-20 ft. lengths. (Longer lengths available by special order.)

*brackets mounted on 12” centers.



555 Lawton Avenue, P.O. Box 835 | Beloit, Wisconsin 53512-0835
p. 608.365.2161 | f. 608.365.4565 | Toll Free. 800.766.2825 | www.cnbhnp.com

©2006 rev. 6.19.06